

U5:
 V1=high => pin 5 - pin 1
 V2=high => pin 5 - pin 3

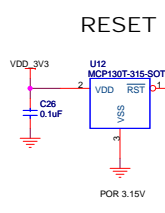

BC5MM-EXT

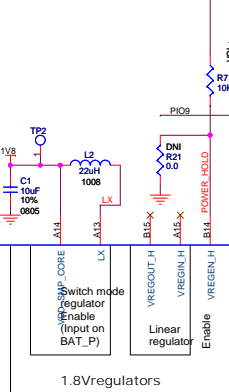
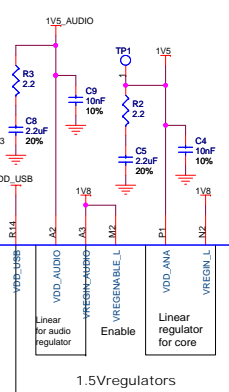
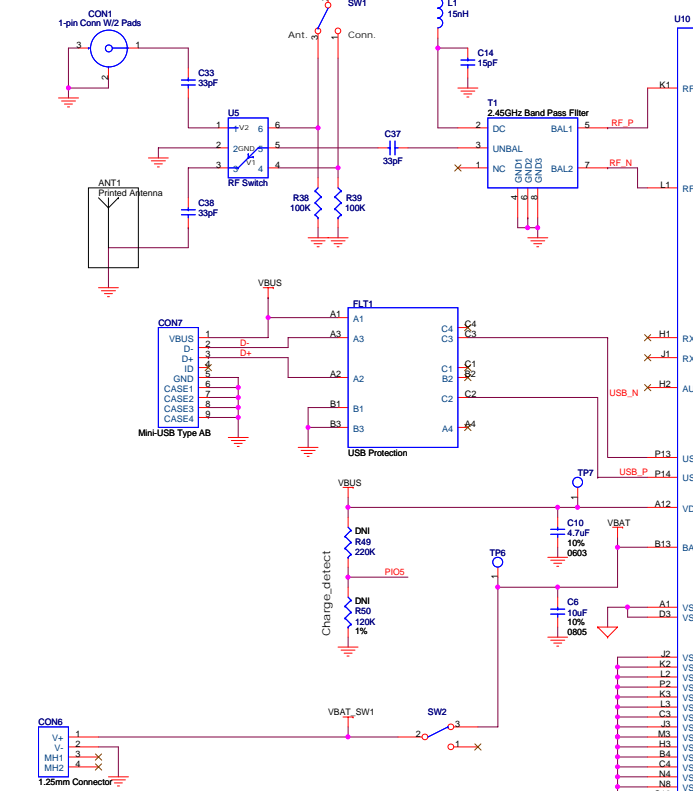
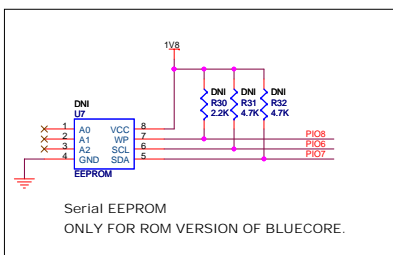
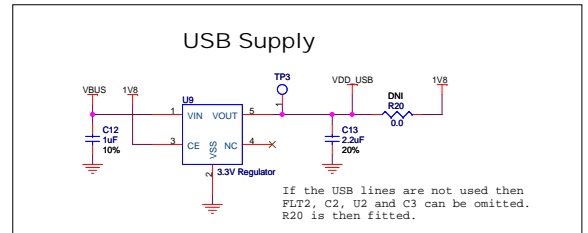
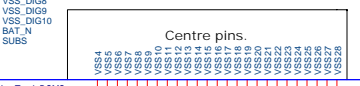

This board can accept all Flash types up to 32Mb in a JEDEC standard pin assignment for x16 memories.

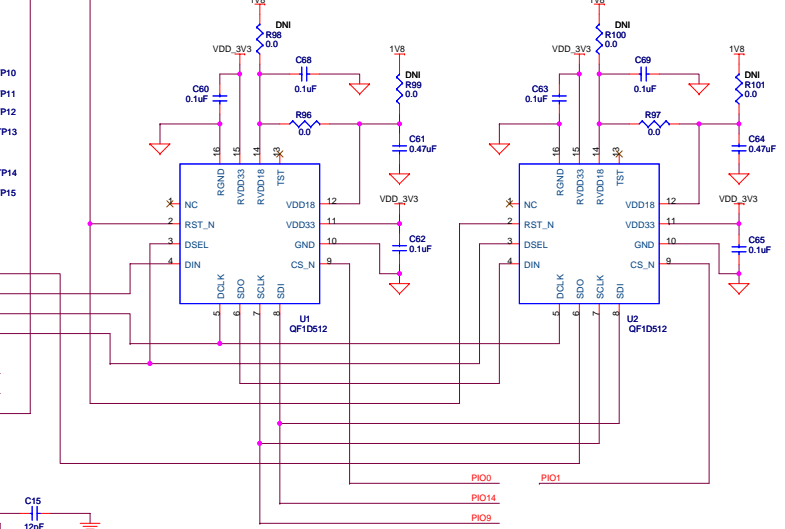
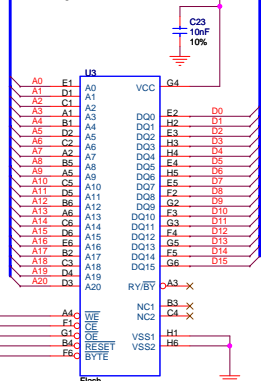

Audio Amp supply

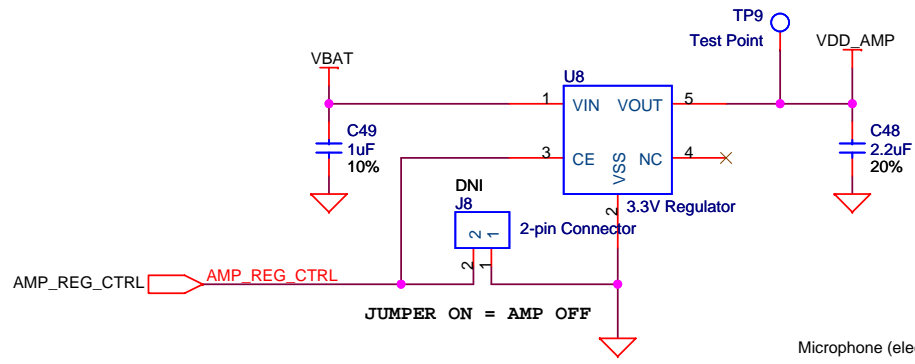

Mid Rail Generation

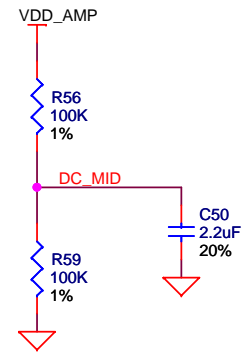

$f_{3dB} = 1/2 * \pi * 220\mu F * 32\text{ohm} = 22\text{Hz}$

Stereo Headset Jack

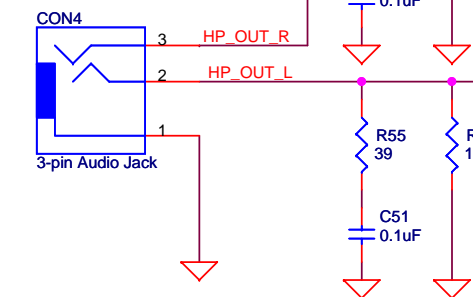

Ext. Speaker Interface

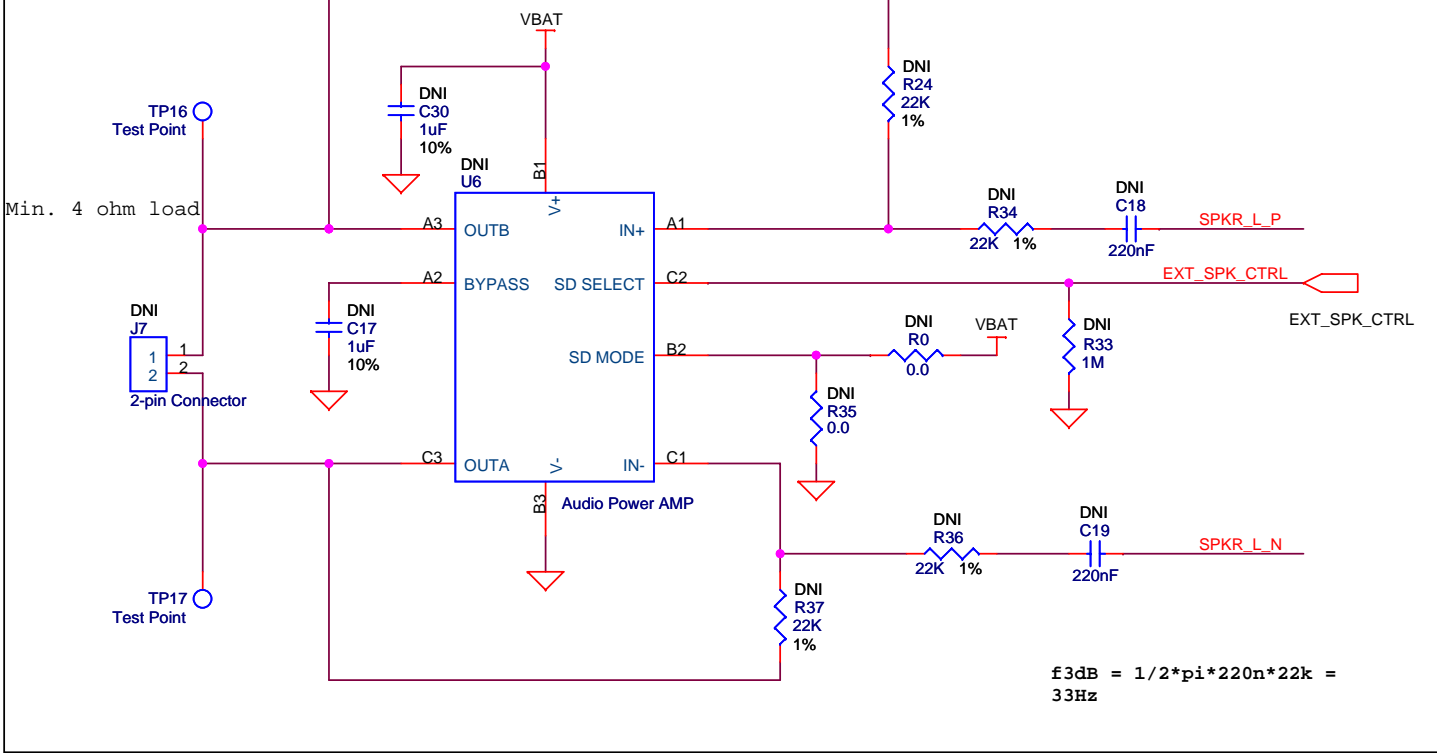

$f_{3dB} = 1/2 * \pi * 220n * 22k = 33\text{Hz}$

BIAS_MIC

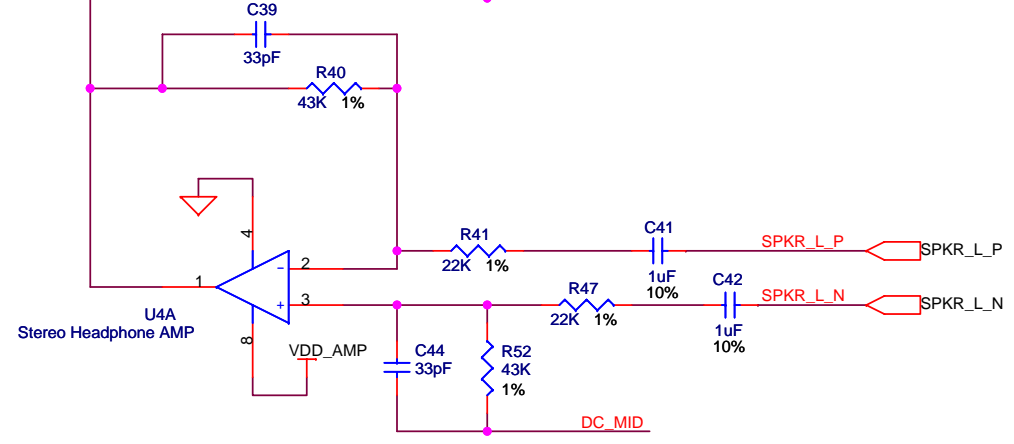
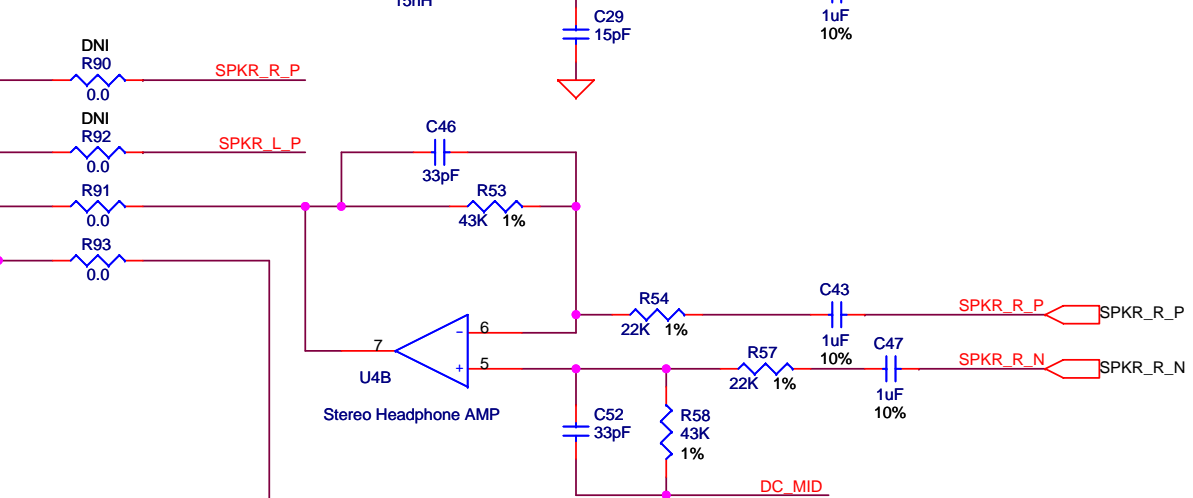

Title		
Quickfilter Technologies		
Size	Document Number	Rev
A3	Blue Mojo	V1.1j
Date:	Monday, September 15, 2008	Sheet 2 of 2