

## 2.1 Single-Filter Design based on the Audio Dragon Block Diagram

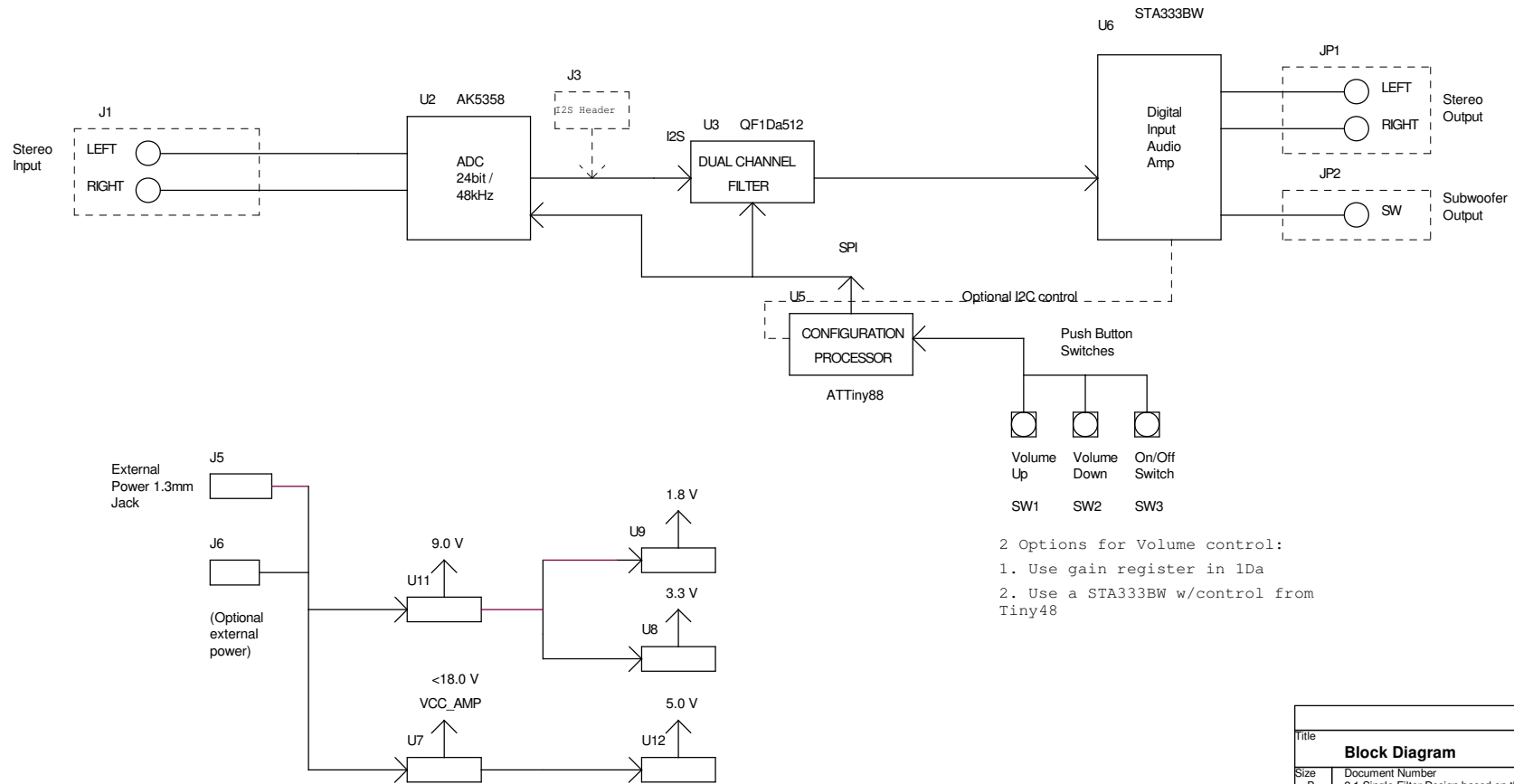

<b>Title</b>		
<b>Block Diagram</b>		
<b>Size</b>	Document Number	<b>Rev</b>
<b>B</b>	2.1 Single-Filter Design based on the Audio Dragon	<b>2.0</b>
<b>Date:</b>	Thursday, January 21, 2010	<b>Sheet</b> 1 of 6

## 2.1 Single-Filter Design based on the Audio Dragon

### Board Interfaces

Analog Input

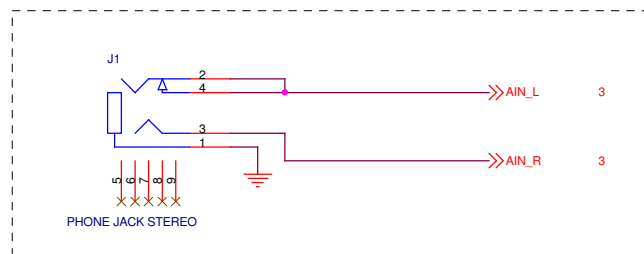

ATTiny Programming Header

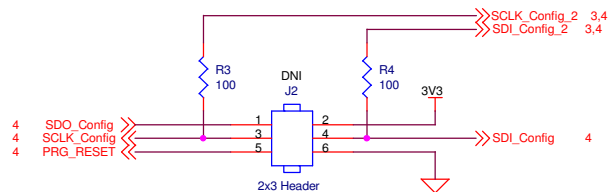

Note not necessary for pre-programmed microcontrollers. Header can be touch pads on bed of nails saving connector cost

Title		
<b>Board Interfaces</b>		
Size B	Document Number 2.1 Single-Filter Design based on the Audio Dragon	Rev 2.0
Date:	Thursday, January 21, 2010	Sheet 2 of 6

# 2.1 Single-Filter Design based on the Audio Dragon

## AK5358

Designed for Stand Alone Mode only

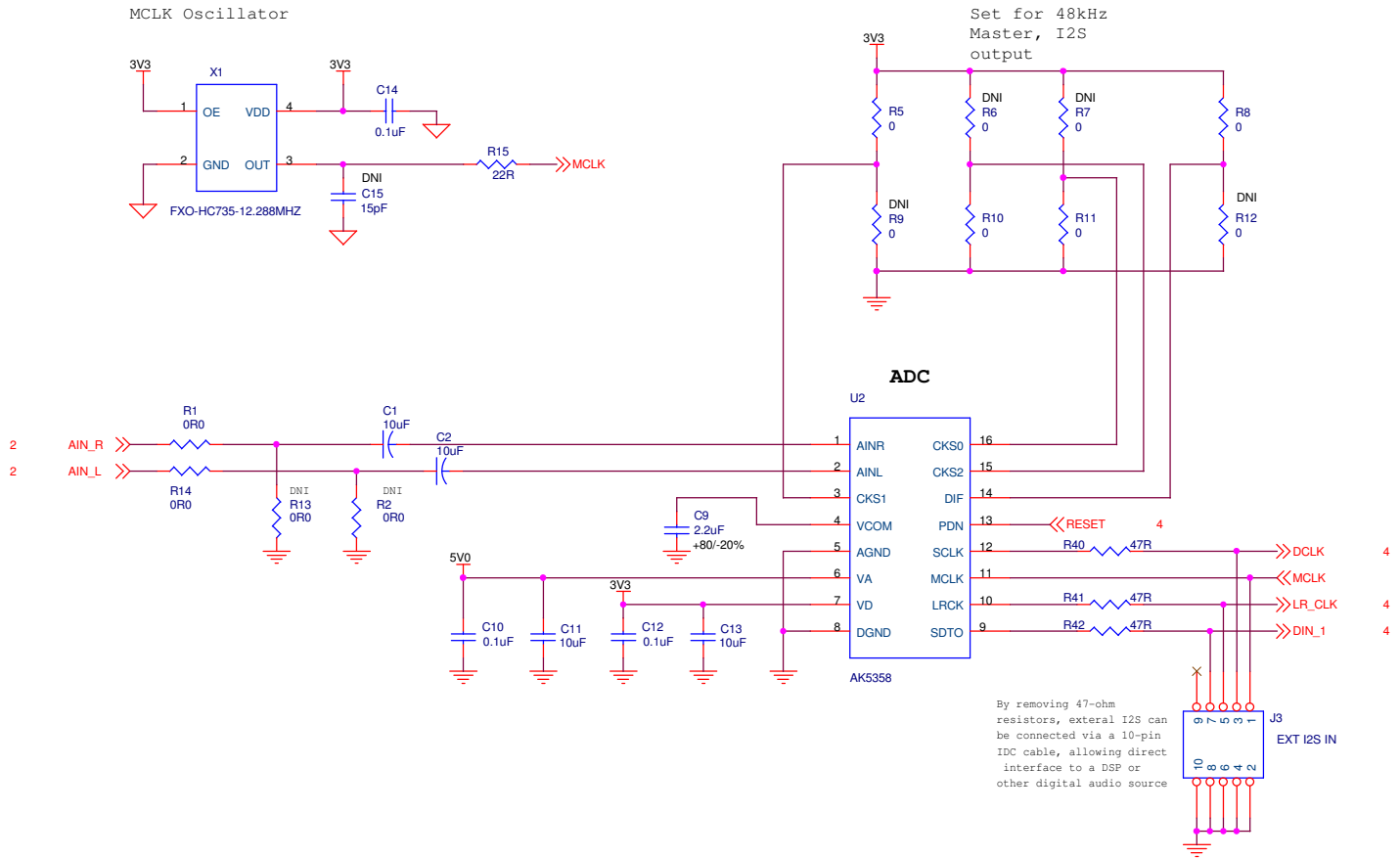

Title		
<b>ADC</b>		
Size B	Document Number 2.1 Single-Filter Design based on the Audio Dragon	Rev 2.0
Date:	Thursday, January 21, 2010	Sheet 3 of 6

# 2.1 Single-Filter Design based on the Audio Dragon

## QF1D512/QF1Da512 Filter

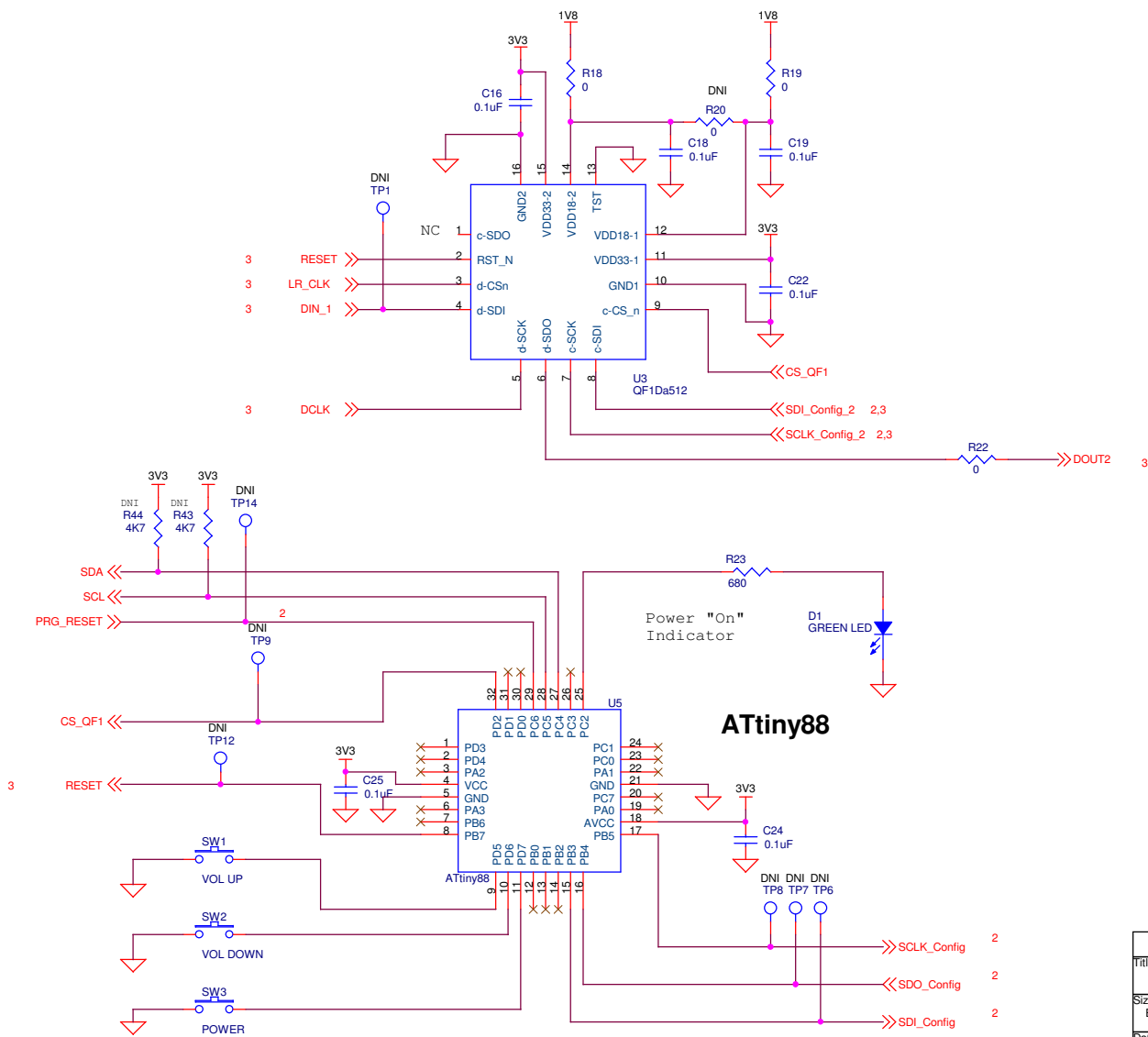

Title		
QF1Da512 & ATTINY48		
Size	Document Number	Rev
B	2.1 Single-Filter Design based on the Audio Dragon	2.0
Date:	Thursday, January 21, 2010	Sheet 4 of 6

## 2.1 Single-Filter Design based on the Audio Dragon

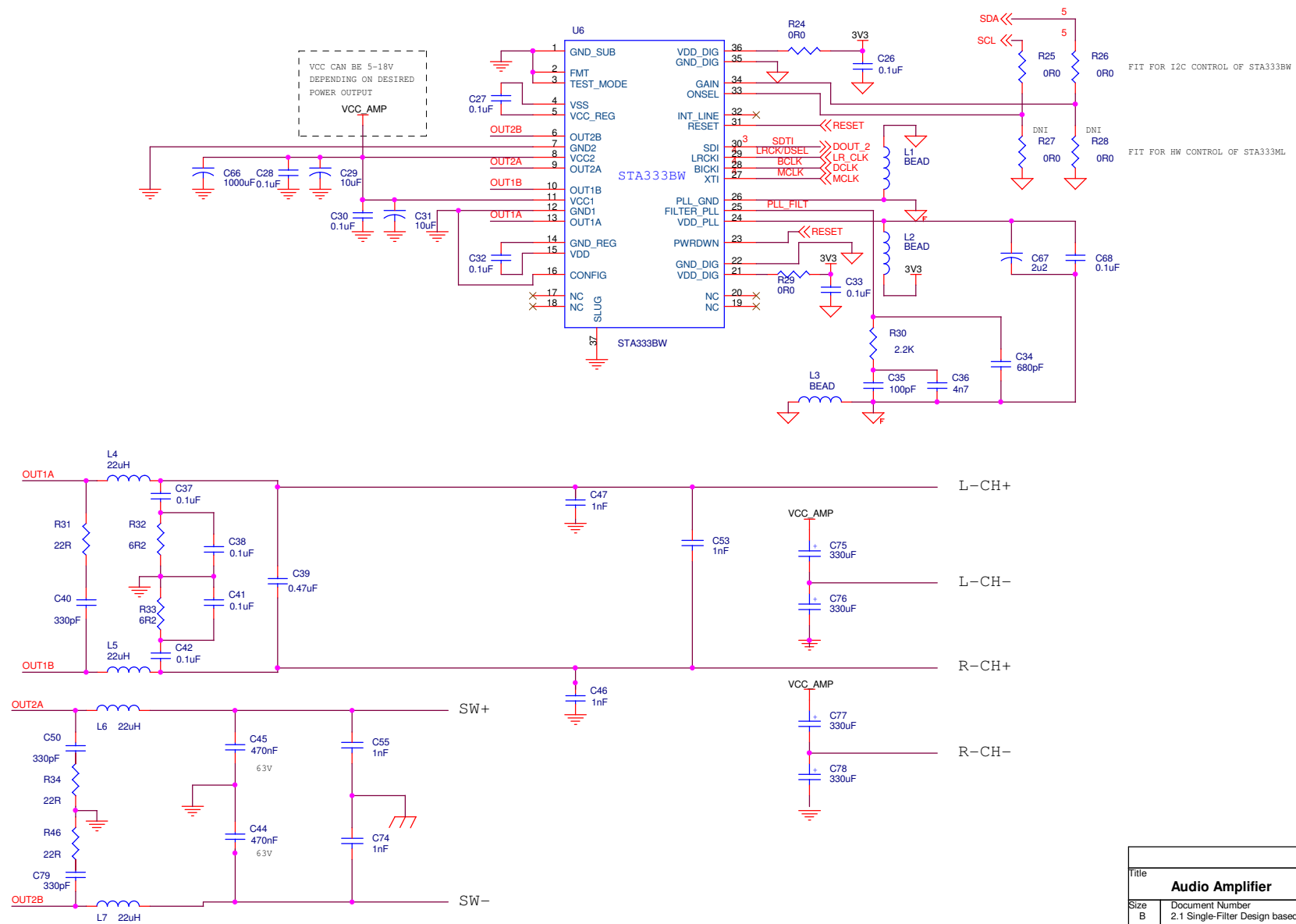

Title		
<b>Audio Amplifier</b>		
Size B	Document Number 2.1 Single-Filter Design based on the Audio Dragon	Rev 2.0
Date:	Thursday, January 21, 2010	Sheet 5 of 6

# 2.1 Single-Filter Design based on the Audio Dragon

## Power Supply

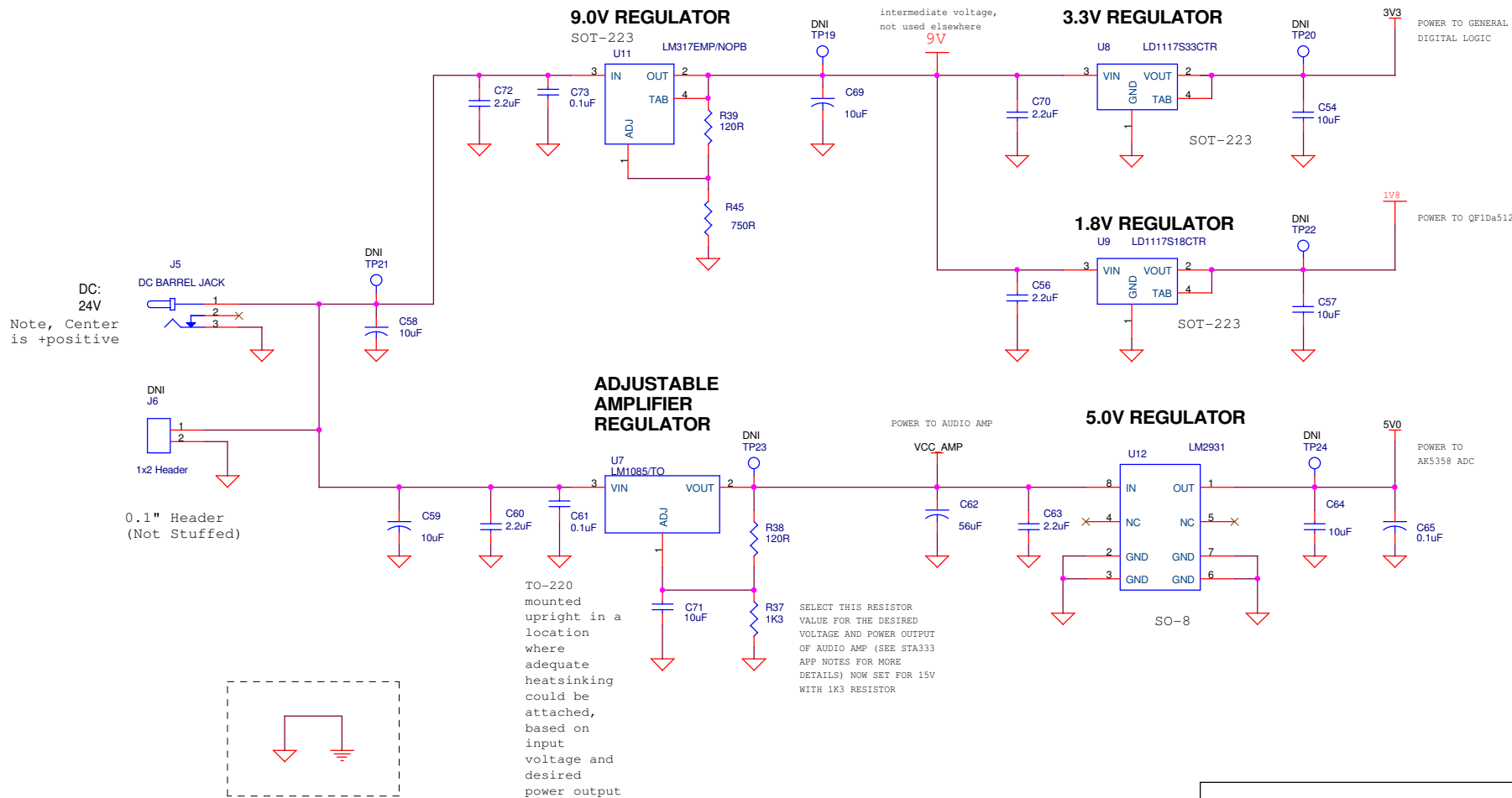

Title		
<b>Power Supply</b>		
Size B	Document Number 2.1 Single-Filter Design based on the Audio Dragon	Rev 2.0
Date:	Thursday, January 21, 2010	Sheet 6 of 6